

# AccuGauge AG100



## Media Isolated Digital Pressure Gauge



The **AG100** series is a media isolated digital pressure gauge featuring multiple measurement units, min/max readings, selectable tare/zero and an automatic power off to conserve battery power. Also, a backlight provides improved visibility under marginal lighting conditions.

The **AG100** will operate with any liquid or gas that is compatible with 17-4PH stainless steel. Please consult the factory for other available wetted materials.

The design of this one-piece sensing element contains no silicone oil, welds or internal O-rings. The **AG100** is ideal for oxygen service, hydrogen\* tanks and other critical applications where fluid filled gauges cannot be used.

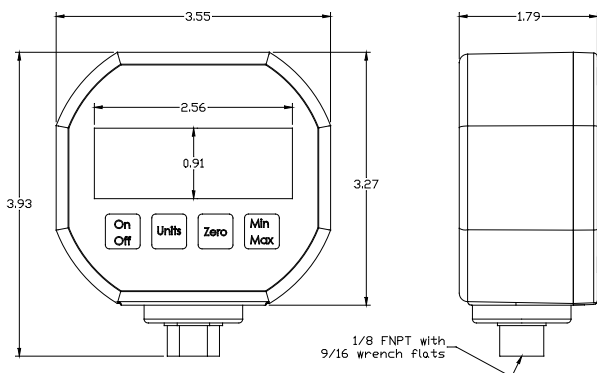

### Performance @ 25°C (77°F)

Pressure Range	A number of preset ranges are available
Measurement Units	PSI, BAR, kg/cm, ATM, InH <sub>2</sub> O, InHg
Accuracy	<±0.5% BFSL (Includes Non-linearity, Hysteresis and Non-repeatability)
Stability (1 year)	±0.25% FS (typical)
Over Range Protection	2X Rated Pressure
Burst Pressure	5X or 20,000 PSI whichever is less
Pressure Cycles	>100 Million

### Environmental Data

#### Temperature

Media	-55 to 125°C (-67 to 257°F)
Operating (Ambient)	-10°C to 70°C (14°F to 158°F)
Storage	-10°C to 85°C (14°F to 185°F)

#### Thermal Limits

Compensated Range	0°C to 55°C (32°F to 131°F)
TC Zero	<±1.5% of FS
TC Span	<±1.5% of FS

### Specifications

Display Update Rate	2 samples per second
Power	9 Volt Alkaline Battery
Automatic Power Off	1 Hour
Battery Life	4000 Hours Operation (typical)
Protection Rating	NEMA 4, IP 65
Instrument Case	Poly carbonate

### Ordering Information

**AG100 A V0100**

#### Series Type

A=1/4" NPT Male  
J= 1/8" NPT Female

Pressure range  
Insert 5-digit pressure  
range code

#### Pressure Ranges

Gage PSIG	Pressure Range Code
-14.7 to 50	V0050
-14.7 to 100	V0100
-14.7 to 250	V0250
-14.7 to 500	V0500
-14.7 to 1000	V1000
0 to 2500	02500
0 to 5000	05000



## AG100 Operating Instructions Rev 1.1

### **ON OFF**

Press and release this button to turn the AccuGauge ON. Press and hold this button to turn the AccuGauge OFF. When the AccuGauge is ON press and release this button to turn on the backlight. The AccuGauge will automatically turn OFF after one hour to conserve battery power.

### **BACKLIGHT**

The backlight of the AccuGauge will illuminate the LCD display for 10 seconds anytime one of the four buttons is pressed. To turn on the backlight without changing the display, press and release the ON/OFF button.

### **UNITS**

Press the UNITS button to cycle through the units of measurement the AccuGauge can display. The AccuGauge can measure pressure in PSI, BAR, Kg/cm<sup>2</sup>, Inches Hg, Inches H<sub>2</sub>O and ATM. The unit of measurement can be changed at any time and will not affect the operation of the AccuGauge.

### **RELATIVE PRESSURE**

Press and release the ZERO button to place the AccuGauge in relative pressure mode. The REL symbol will be displayed at the top of the LCD to indicate the gauge is operating in relative pressure mode. The display will rezero at the applied pressure that was acting on the Gauge at the moment the button is pressed and display pressure readings +/- relative to that pressure. Press this button again to return to GAUGE mode of operation, which displays pressure relative to the local pressure.

### **ZERO**

Over the course of time it may become necessary to reset the AccuGauge to zero. Press and hold the ZERO button until the REL symbol appears and disappears and the display reads zero pressure in the selected units of measurement. Release the ZERO button and the display will read zero pressure in the current units selected.

### **MIN MAX**

The MIN MAX button allows the user to read the minimum and maximum pressure the AccuGauge has detected during the time that the gauge has been on. These readings are not saved and reset every time the gauge is powered off. Press the MIN MAX button once and the MIN symbol will be displayed along with the minimum pressure, press the MIN MAX button again and the MAX symbol will be displayed along with the maximum pressure. Press the MIN MAX button again and the MAX symbol will disappear and the gauge will display the current pressure. Press and hold the MIN MAX button to reset the minimum and maximum pressure readings.

### **LOW BATTERY**

The AccuGauge has a battery condition indicator in the upper left corner of the LCD display. The indicator is composed of a battery symbol and four vertical bars. As the battery discharges the vertical bars will disappear from right to left. When all four bars have disappeared the battery is nearly discharged. As a final warning the symbol LOW BAT will be displayed and indicates the battery is nearing complete discharge and should be changed immediately. For best results replace the battery immediately. Use only Alkaline or Lithium 9V batteries.

### **BATTERY REPLACEMENT**

(NOTE: DO NOT open the AccuGauge unless it is necessary to change the Battery.) To replace the AccuGauge's Battery, use a Phillips Head screwdriver to remove the four screws from the back plate of the gauge. Unplug the battery cable from the battery terminals. Remove the battery from the battery holder. Put a new battery into the holder, ensuring that it is firmly in place. Plug the battery cable into the terminals of the battery. Make sure that the polarity is correct. Replace the cover firmly in place. Replace the four screws.

## Warranty

**Workmanship** - AST, Inc. pressure transmitters have a limited one-year warranty to the original purchaser. AST, Inc. will replace or repair, free of charge, any defective transmitter. This warranty does not apply to any units that have been modified; misused, neglected or installed where the application exceeds published ratings. AST's sensors are made with pride in New Jersey, USA. If in the area please feel free to stop by for a visit!

**Installation/Applications** - The purchaser is responsible for media compatibility, functional adequacy, and correct installation of the transmitter.